

1 Accessories

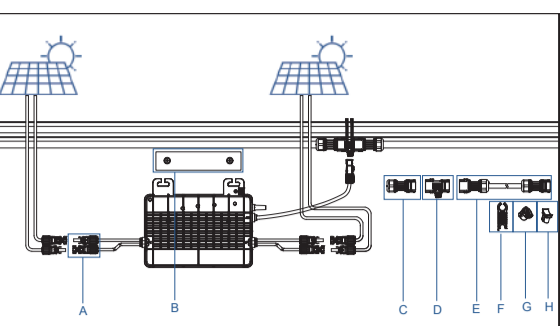

Item	Description
A	PV connectors
B	M8 * 25 screws (Prepared by the installer)
C	AC Male connector
D	AC Trunk Connector
E	AC Trunk Cable 12/10AWG Cable
F	AC Trunk Disconnect Tool
G	AC Trunk End Cap
H	AC Trunk Port Cap

*Note: All accessories above are not included in the package and should be purchased separately. Please contact Fox ESS sales for the latest sales price.

2 Installation Steps

The order of Step 1 and Step 2 can be reversed according to your planned needs.

Step 1. Plan and Install the Microinverter

- Mark the position of each microinverter on the rail according to the PV module layout.
- Fix the screws on the rail.
- Hang the microinverter on the screws, and tighten the screws. The silver cover side of the microinverter should be facing the panel.

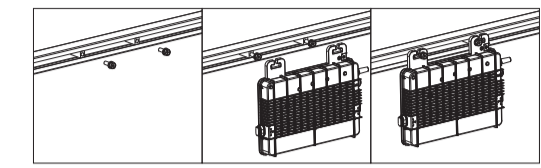

Note:

- There is an earth wire inside the wire cable and the grounding can be done directly by this wire. If external grounding is needed, the grounding electrode, as shown on the right, can be used to bond the mounting bracket to the racking. Torque each grounding lead screw to 2 Nm.
- Install the microinverter and all DC connections under the PV module to avoid direct sunlight, rain exposure, snow buildup, UV, etc.
- Leave at least 2 cm of space around the microinverter enclosure to ensure ventilation and heat dissipation.
- Mounting torque of the 8 mm screws should be 9 N·m. Please do not over-torque.
- Do not pull or hold the AC cable with your hand.

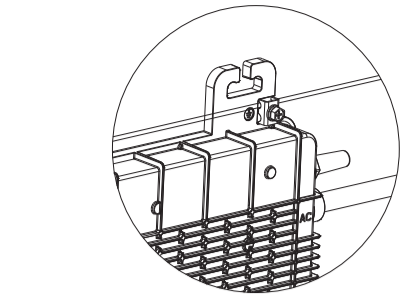

Step 2. Plan and build the AC Bus Cable

- Select the appropriate AC Trunk Cable according to the spacing between microinverters. The connector spacing of the AC Trunk Cable should be close to spacing between microinverters to ensure that they are well-matched. (Hoytles provides AC Trunk Cable with different AC Trunk Connector spacing.)
- Determine how many microinverters you plan to install on each AC branch and prepare AC Trunk Connectors accordingly.
- Take out segments of AC Trunk Cable as you need to make AC branch.

- Strip the AC cable with suitable length to connect to the distribution box, with stripping requirements fulfilled.

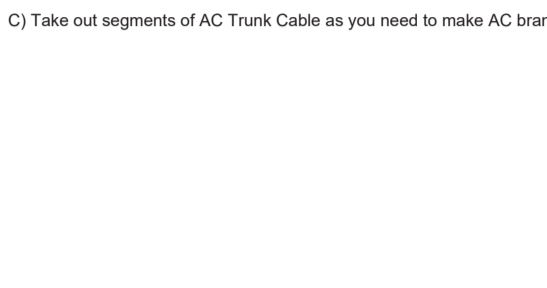

1) Installation of the AC bus (as shown)

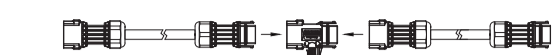

- Run the cable into the sleeve assembly (AC Male connector)



- Pushing terminal into the body.



- Insert Seal and Clamp Finger into body, then tighten the nut, torque 2.5±0.5N·m



- Male and female connectors connected.

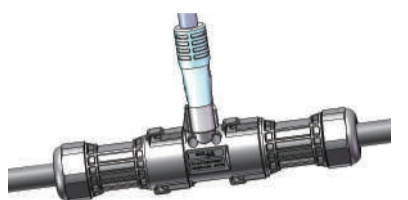

Note:
1. Tightening torque of the cap: 2.0±0.5 N·m. Please do not over-torque.
2. Do not damage the sealing ring in the AC Trunk Connector during disassembly and assembly.
3. In case you need to remove the Inverter AC cable from AC Trunk Connector, please use the Tool and insert the tool into the side of AC Sub Connector to complete the removal.
4. Repeat the above steps, lay out the cable on the rail as appropriate so that the microinverters can be connected to the Trunk connectors.
5. Attach the AC Trunk Cable to the mounting rail and fix the cable with tie wraps.

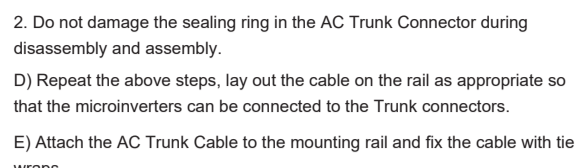

Step 3. Complete the AC Connection

- Push the AC Sub Connector from microinverter to the AC Trunk Connector until it clicks.

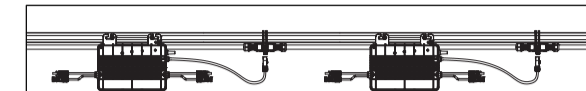

- Connect the AC end cable to the distribution box, and wire it to the local grid network.

- Please plug the AC Trunk Port Cap in any vacant AC Trunk Port to make it water and dust-proof.

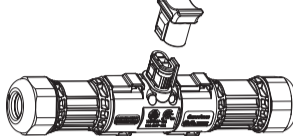

Note:
1. Make sure that the AC Trunk Connectors are kept away from any water-channelling surface.
2. In case you need to remove the Inverter AC cable from AC Trunk Connector, please use the Tool and insert the tool into the side of AC Sub Connector to complete the removal.

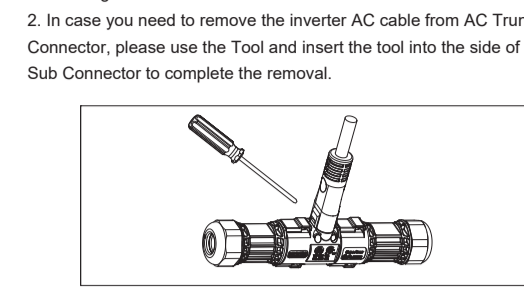

Step 4. Create an Installation Map

- Peel the removable serial number label from each microinverter.
- After the serial number label to the respective location on the installation map (please refer to the User Manual).

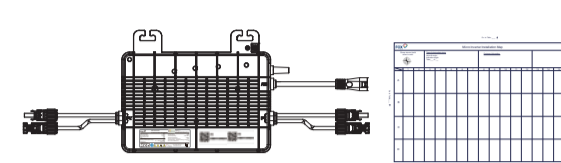

Logic Description:

- normal disconnection: change MeshID, configure member list
- initial state, meshID is undefined, every time you enter the allocation web page, APP randomly generates and sends MeshID to the device along with the allocation network instruction. (Reset to the initial state method: equipment access to the network, the member list is set to send empty, or member devices do not add the device (provided that the device is not networked))
- After the device writes the MeshID, every time you enter the APP, the MeshID is read in the device.
- The device cannot be added to the member list when it is not connected to the network, and the device can be added to the member list when it is not connected to the network. When the device is in more than one group unit, it will be added randomly, and will not change after joining one group unit. If the SN is not in the list, it means that there is no Bluetooth in the vicinity.
- Delete other devices in the member list, and the other devices return to the initial state.

Bluetooth

Select the appropriate SSID and enter the password, click OK, prompting Success!

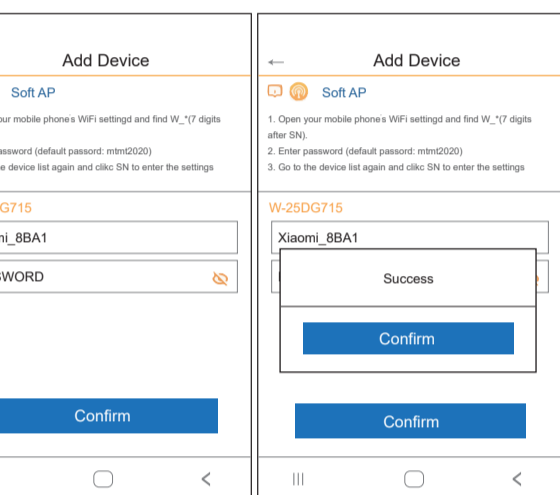

WiFi Mesh

The inverter list prompts for success, click to return to the Add Device-WiFi Mesh device selection page, or wait for the APP to detect it and automatically return to the previous page.

Step 2: After returning to the WiFi Mesh device selection page, wait for 30s, click the Refresh button on the upper right corner, Group xxx-xxx-xxx, and the column of ungrouped devices will appear, check Group, and in the column of ungrouped devices, check the SN corresponding to the purchased device, and then click Confirm, and enter the WiFi Mesh page.

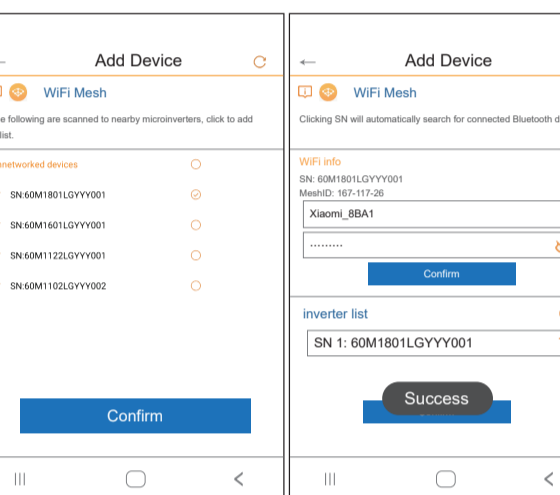
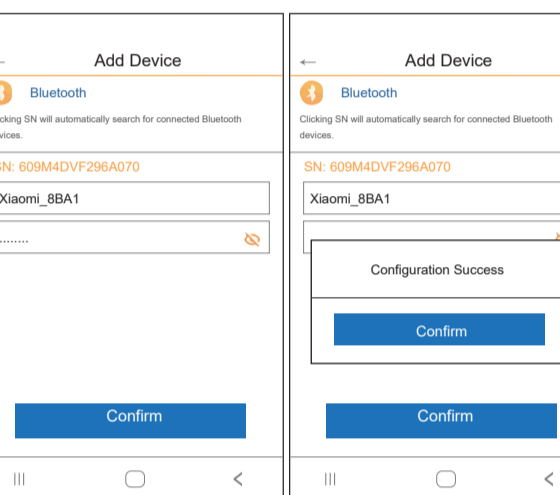

Step 2:

After Step 1 prompts for success, click to return to the Add Device-WiFi Mesh device selection page, or wait for the APP to detect it and automatically return to the previous page.

Step 3: After returning to the WiFi Mesh device selection page, wait for 30s, click the Refresh button on the upper right corner, Group xxx-xxx-xxx, and the column of ungrouped devices will appear, check Group, and in the column of ungrouped devices, check the SN corresponding to the purchased device, and then click Confirm, and enter the WiFi Mesh page.

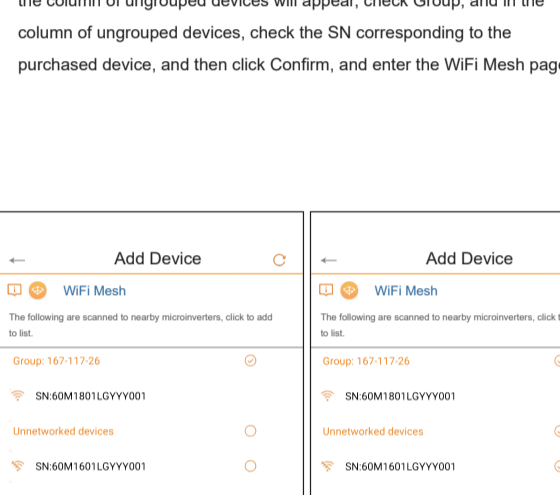

Step 4:

The inverter list lists the devices selected on the previous page, if you still need to add, you can click to add more than one SN. If you make a mistake in the input, you can click the corresponding SN after.

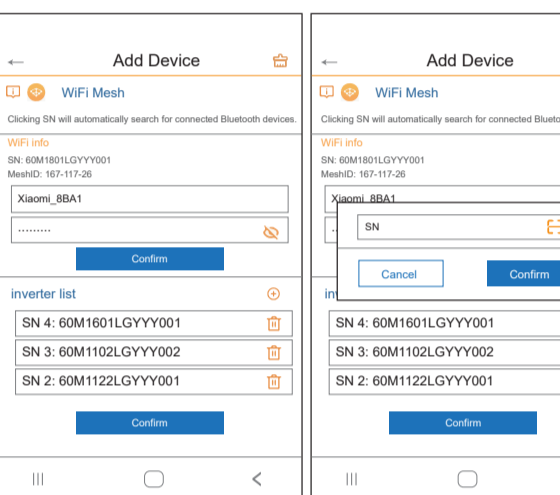

Step 5:

After you add the SN in step 4, click Confirm, and when prompted for success, the operation is complete and you can click.

Description: Device network is normal. Device network is abnormal.

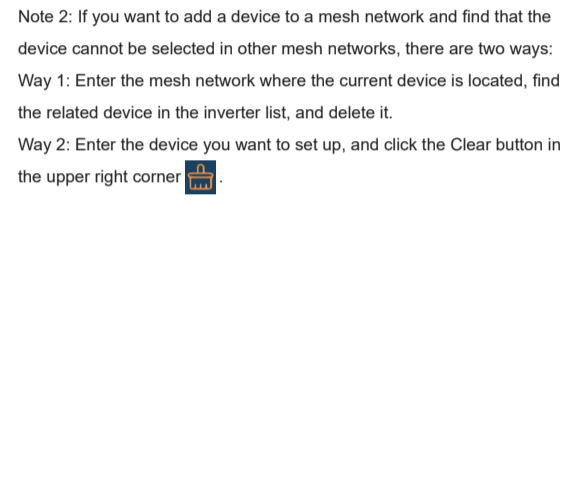

3 Configuration

Prerequisites: Turn on the cell phone WiFi, Bluetooth, positioning, and allow APP to use WiFi, Bluetooth, positioning, then turn it on again, and then check the support network type and description: in the Device page, click the connection after the.

For the first time, click the "*" sign on the upper right corner of the Device page to enter the Add Device page, enter or scan the product and click Confirm, different products correspond to different setting pages.

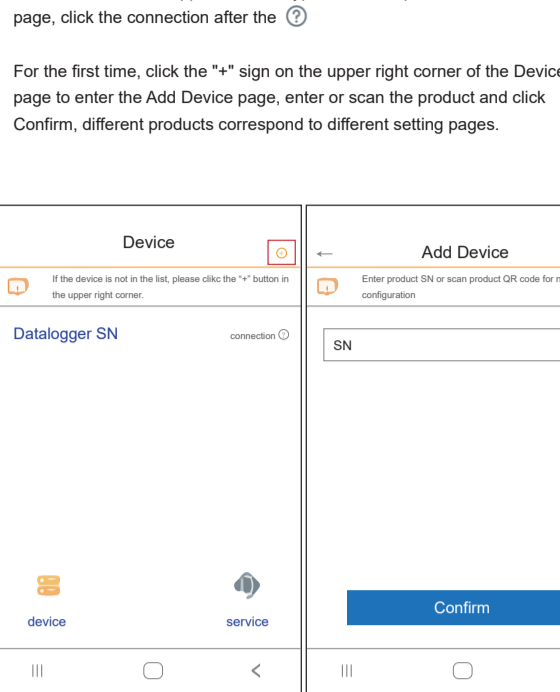

Device saves the previously operated SN, and each subsequent operation can be accessed by clicking directly on the Device page.

Soft AP

Step 1: In the WiFi settings page, select the device WiFi, click Back.

Step 2: Select the appropriate SSID, and enter the password, click OK, prompted by success.

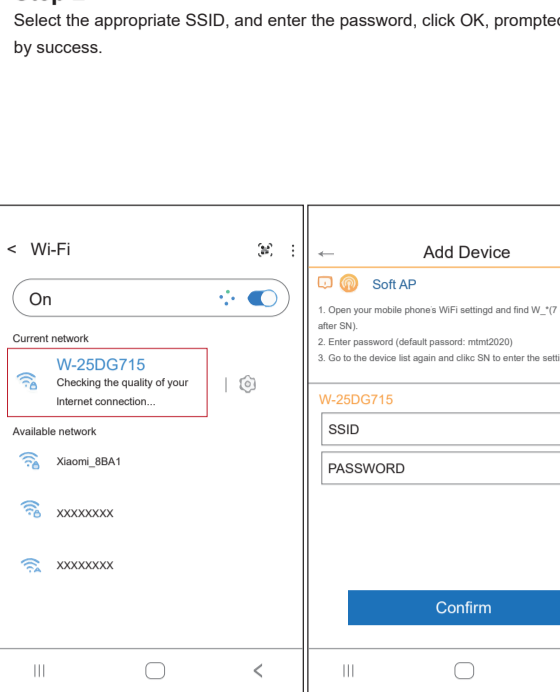

4 Create A Site (APP)

Step1: Log in and enter the page of 'My site'.

Step2: Click "+" and choose "Micro Inverter". Then enter the site-creating page.

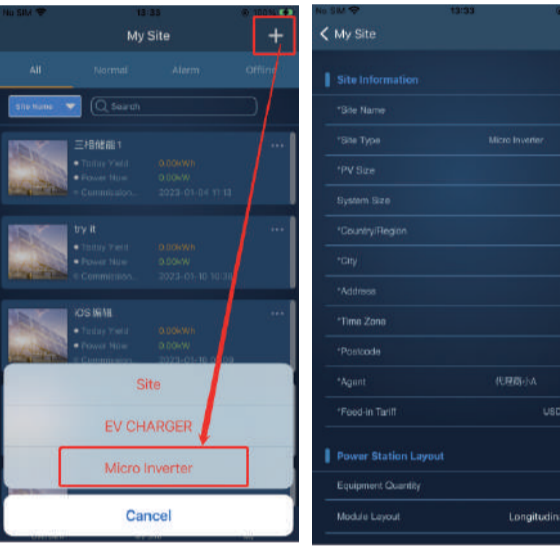

Step3: Input Site Information as requested. Click "OK" and enter Module Layout page.

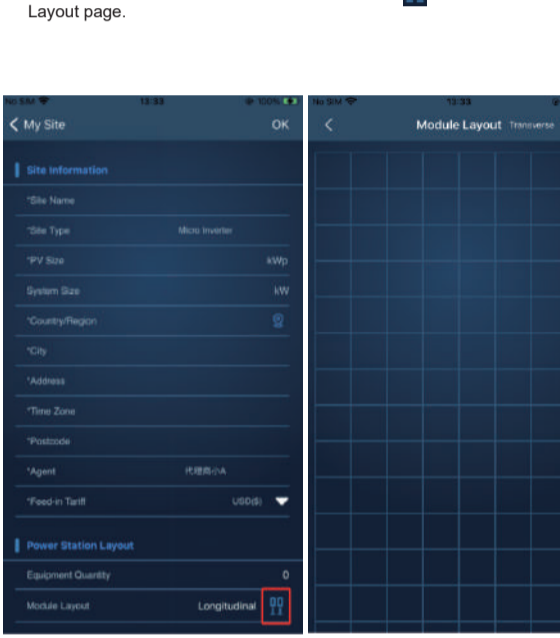

Step4: Click to choose Transverse or Longitudinal layout

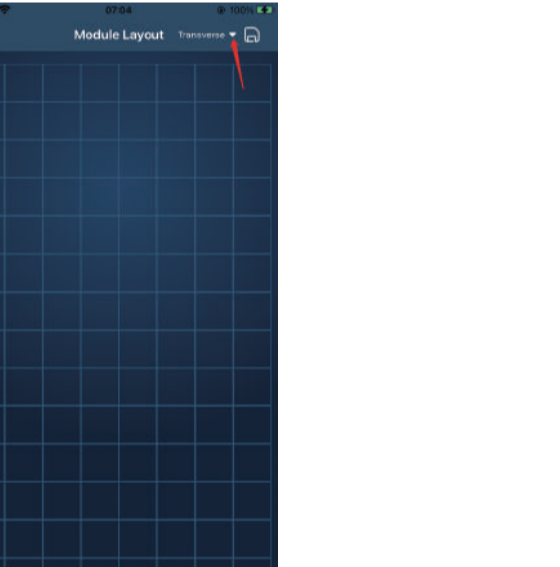

Step5: Click on the grid to select the appropriate location. Fill the relevant information in the "Micro Inverter Parameters" pop-up window.

The added Micro Inverter modules can be seen in the component layout after confirmation. Click on the Save button, then the page returns to "My site". Click confirmation. After that, creation of Micro Inverter site is completed.

Tip: Click "OK" You can measure the Azimuth and Inclination Angle as well as the Direction from your cell phone. Or you can manually enter the Azimuth and Inclination Angle and select the Direction.

Note: Module Layout - Transverse or Longitudinal are not connected!

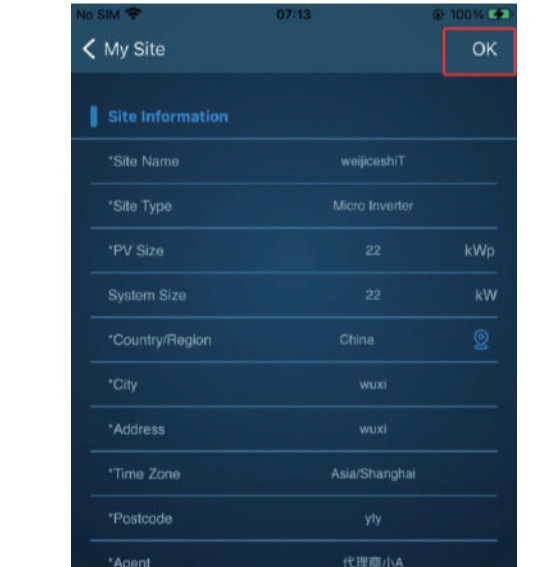
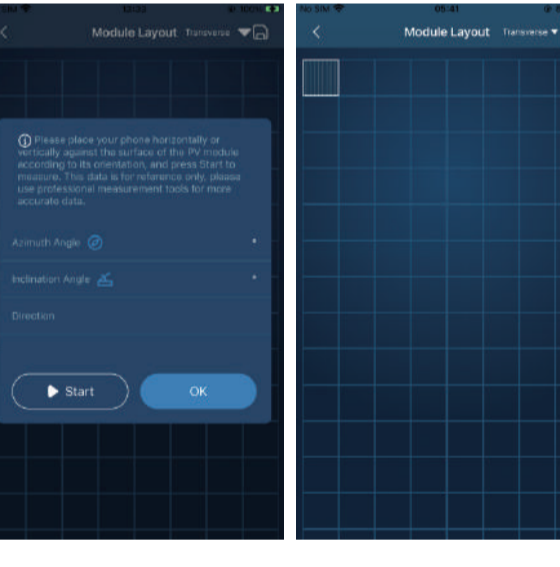
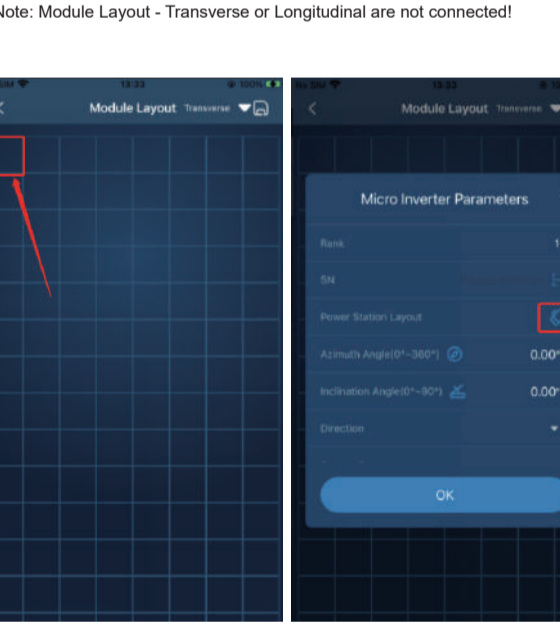

Delete Micro Inverter modules

Edit Site page (Select the site needed editing in the list. Click "OK" and enter the "edit" page.)

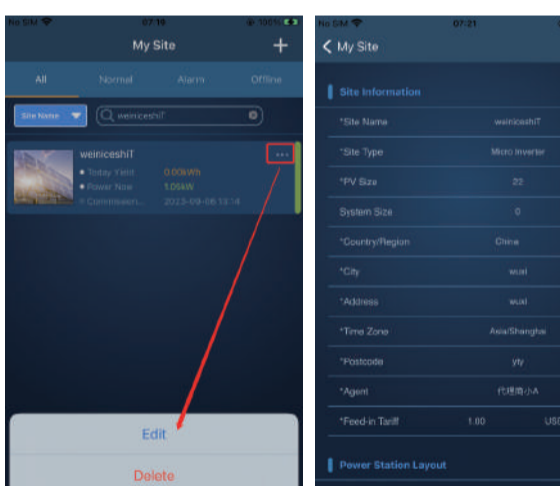

Step1: Click "OK" and enter Module Layout page on the Edit/Create Site page.

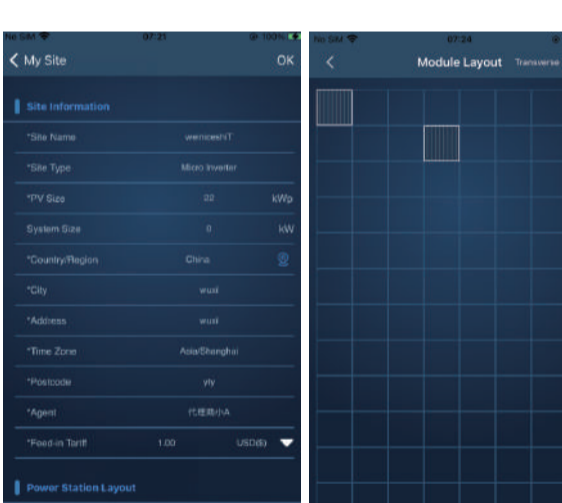

Step2: Click the existed modules to bring up the Micro Inverter Parameters pop-up window on the Module Layout page. Click the Delete button in the Micro Inverter Parameters pop-up window and save it.

Note: Keep at least one micro inverter module in the site.

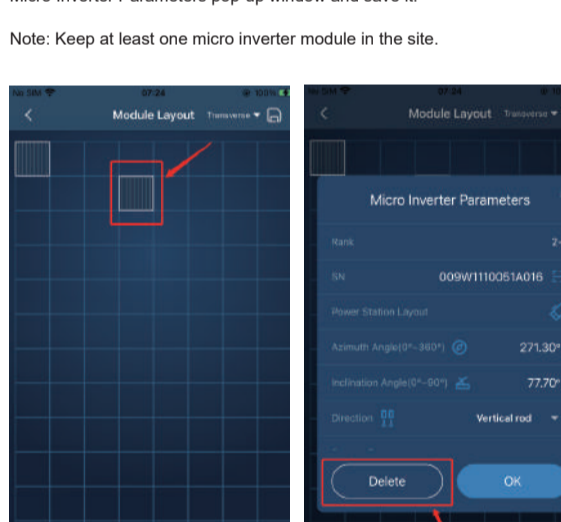

Replay power/generation

Step 1: Click Micro Inverter site to enter the site overview page on the Site List Page.

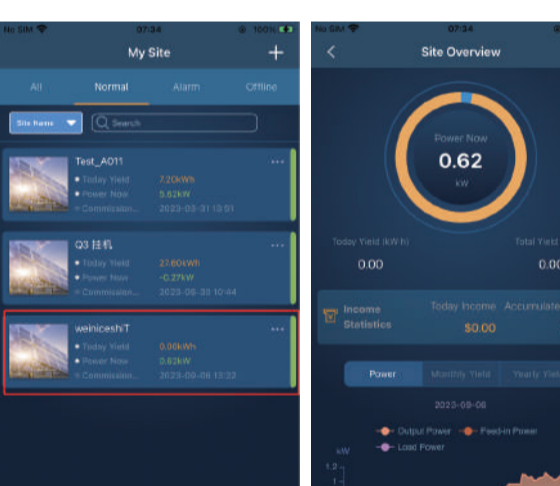

Step 2: Choose to view power/generation and click "OK" and enter the transverse screen page.

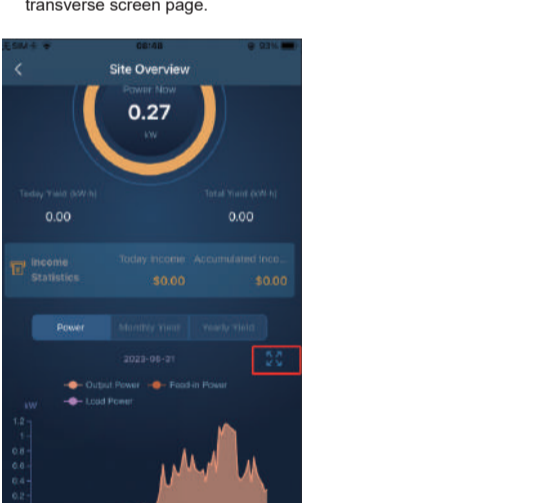

5 Creating Micro Inverter Power Station

Step 3: Click on the replay button "OK" or click on the graph/bar graph manually to view the power/generation at a particular moment.



Step 1: Enter the page of New Site, and select "Micro Inverter site" for site type.

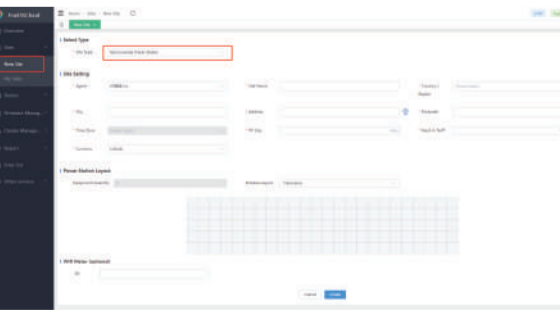

Step 3: Select the appropriate location in the grid and click it. Enter the correct information in the Micro Inverter Parameters pop-up window and click to confirm.

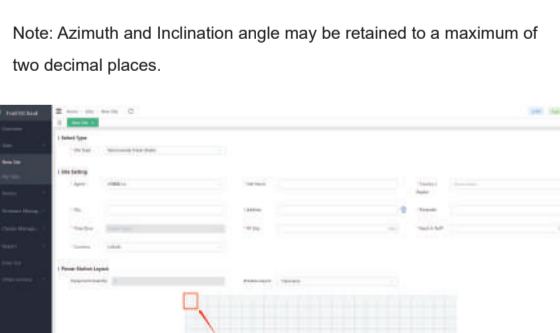

Note: Azimuth and Inclination angle may be retained to a maximum of two decimal places.

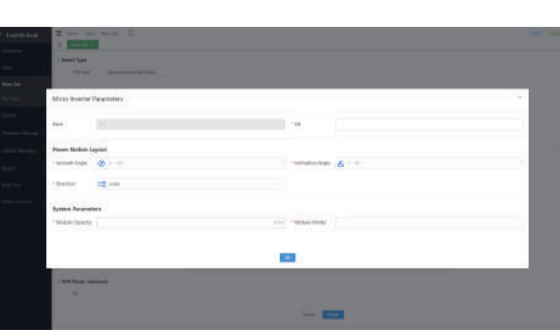

Step 4: Click the create button after filling all the information. Then the creation of the Micro Inverter Power Station is completed.

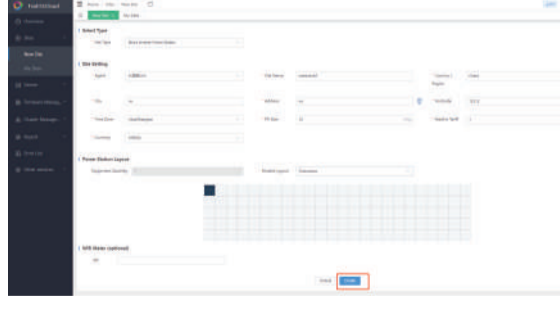

Delete Micro Inverter module

Edit sites page (select the station in the list and click Edit button).

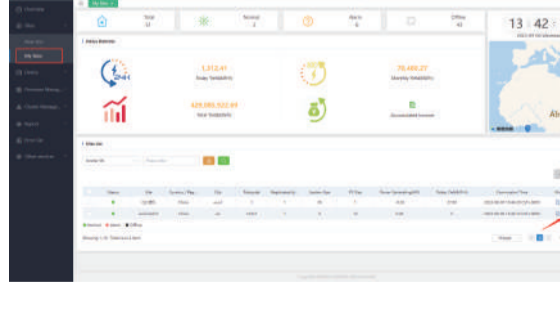

Step 1: Select the Micro Inverter module you want to delete and click.

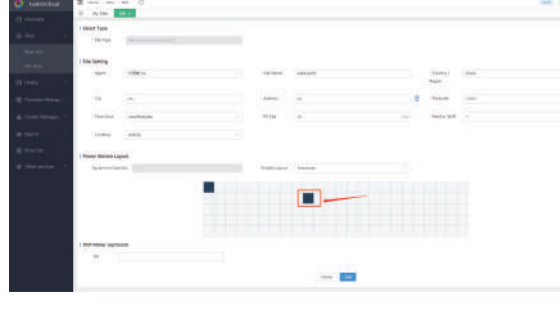

Step 2: Click Delete in the Micro Inverter Parameters pop-up window.

Note: The modules are added incorrectly when creation can be deleted directly.

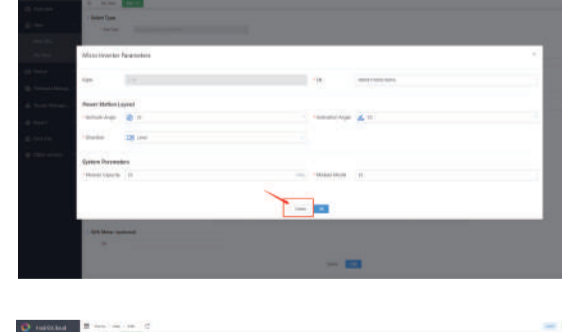

Replay power/generation

Step 1: Select Micro Inverter Site and enter the site details page in the list of my sites

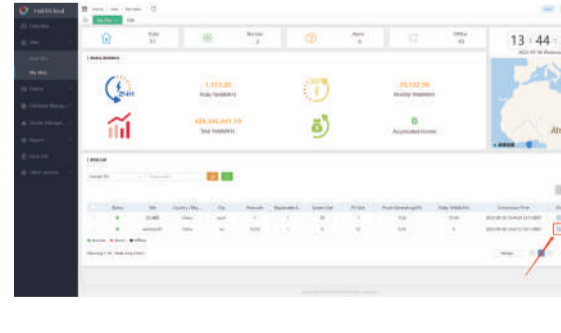

Step2: View Power/Statistics. Click the replay button "OK" or click the graph/bar manually can view the power/generation at a particular moment.



Please scan the QR Code and follow the steps below to download our latest multi-language User Manual/Quick Installation Guide:

Scan the QR Code --> Select your Language --> Choose to download User Manual or Quick Installation Guide --> Download

